

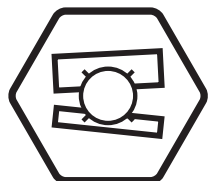

www.blackanddecker.eu

www.blackanddecker.com

WM1000

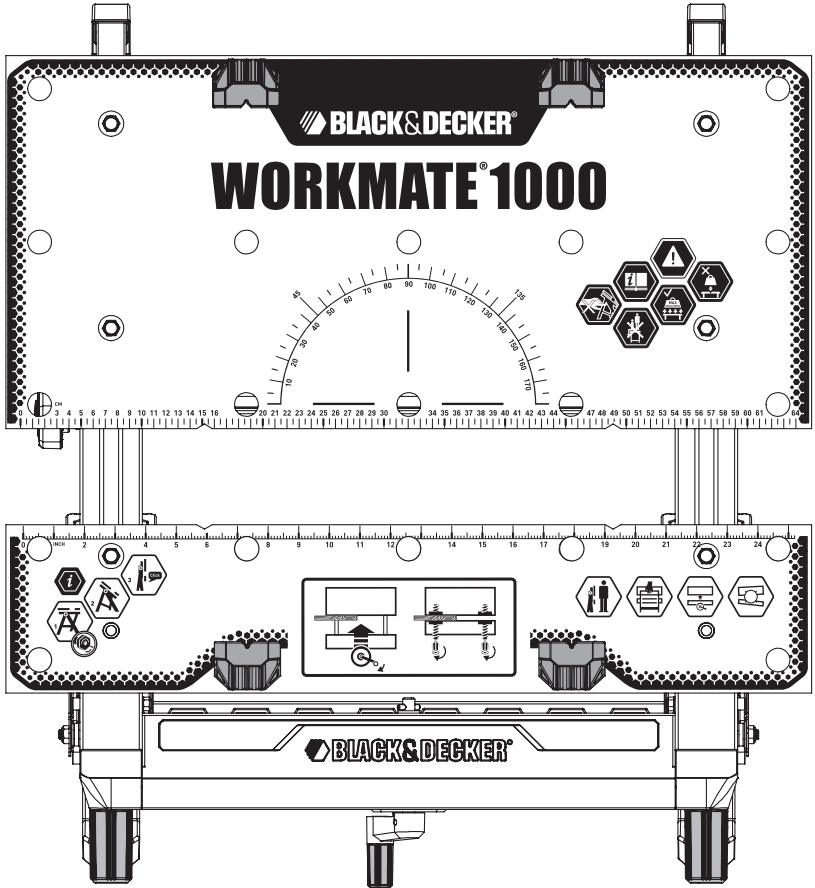

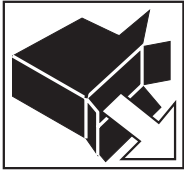

WM00401
(x1)

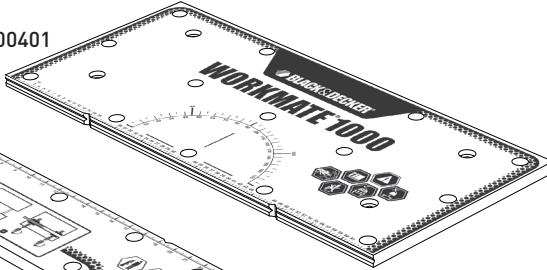

WM00211 (x4)



WM00213 (x2)



WM00314 (x6)



WM00214 (x4)

WM00402
(x1)

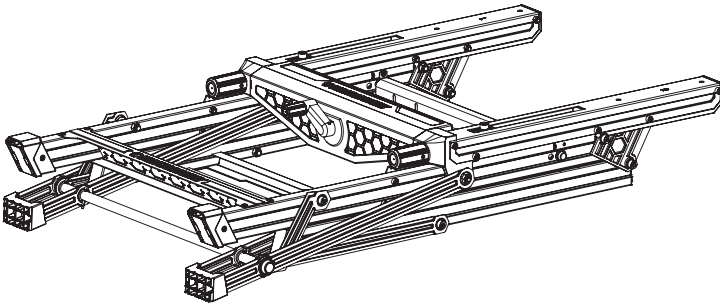
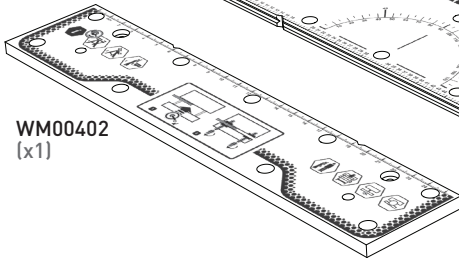

WM00220 (x1)



1

1.1

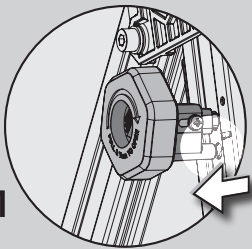

1.2

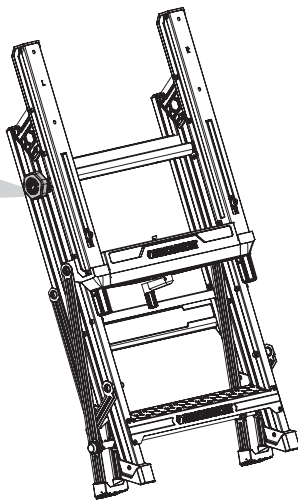
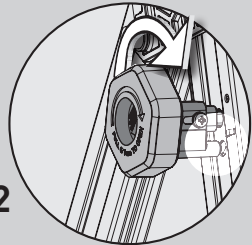

2

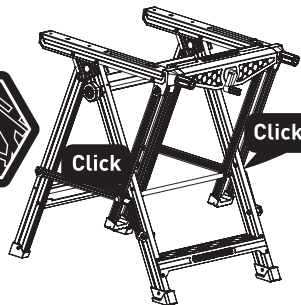
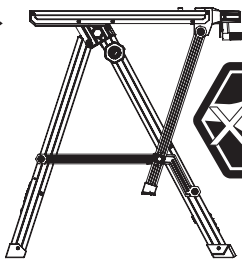
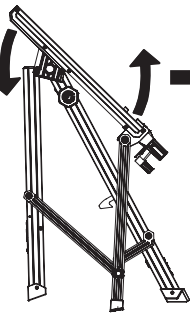
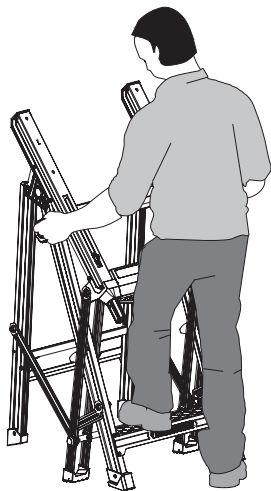

Click

Click

3

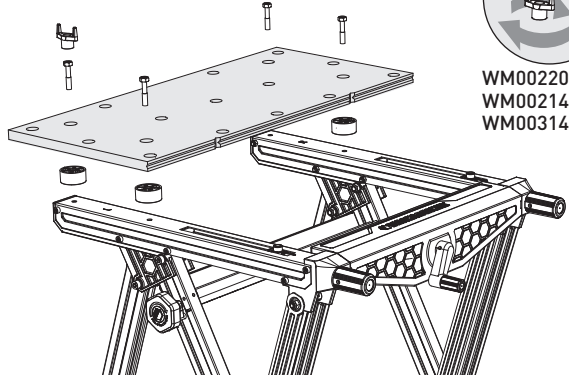
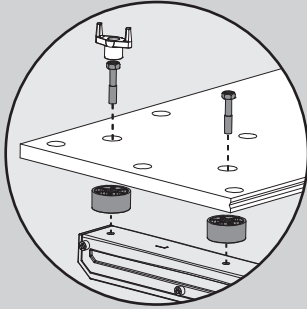

WM00401 (x1)



WM00220
WM00214 (x4)
WM00314 (x4)

4

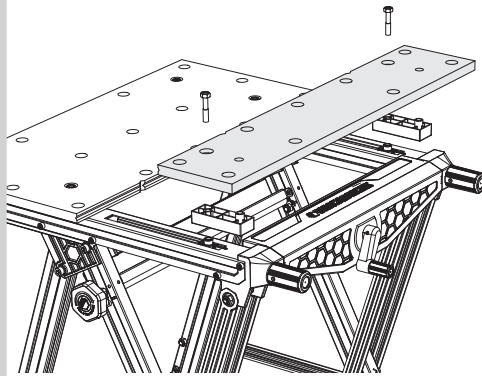
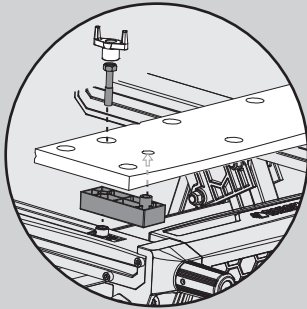

WM00402 (x1)



WM00220
WM00213 (x2)
WM00314 (x2)

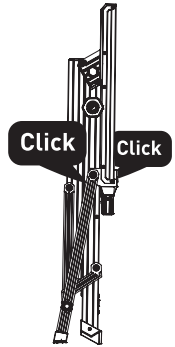
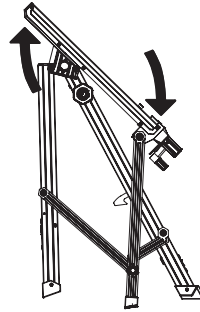
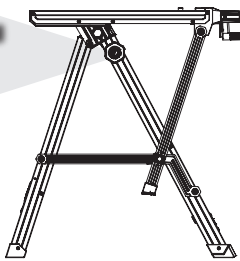
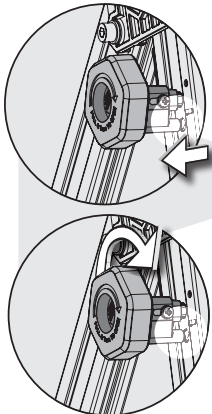

1

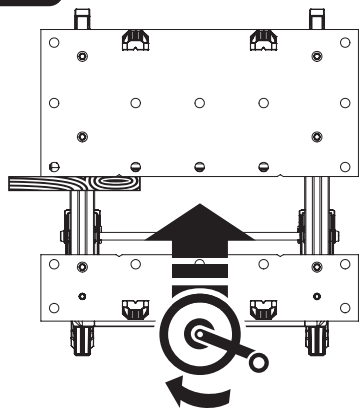

2

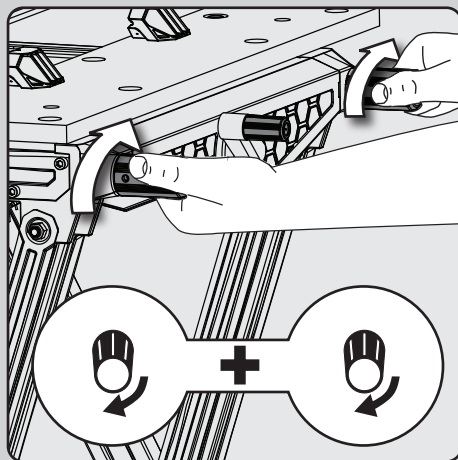
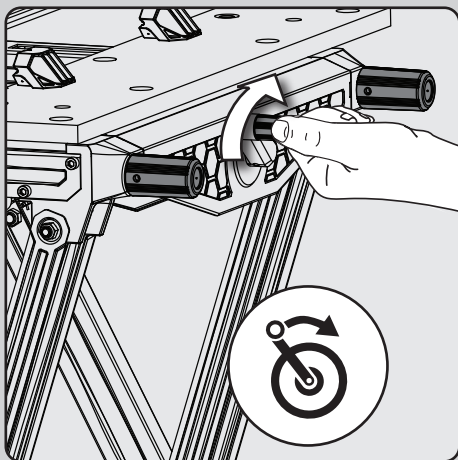
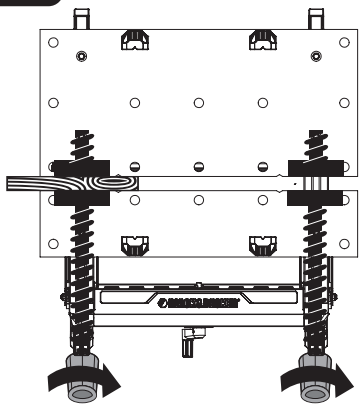

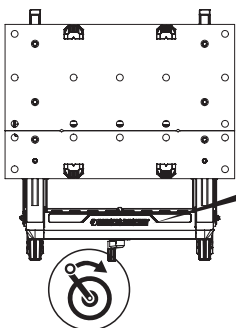
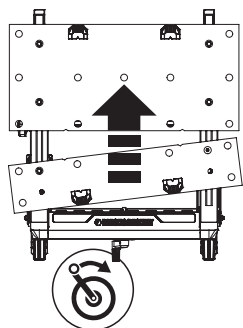
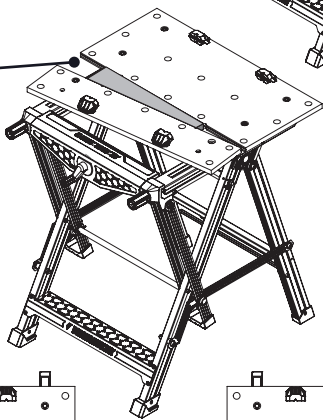
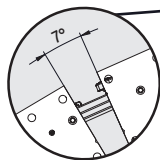
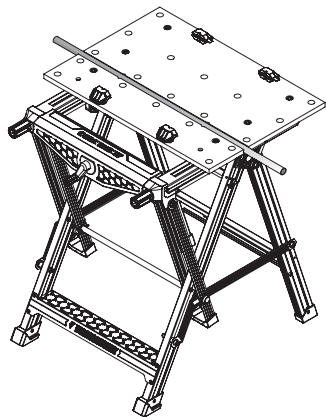
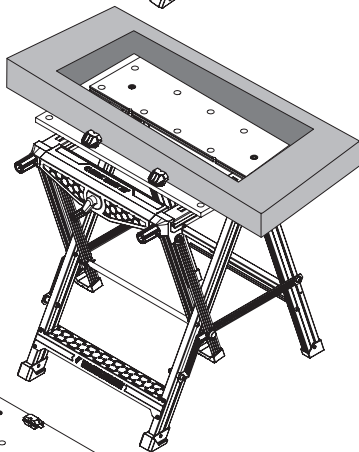
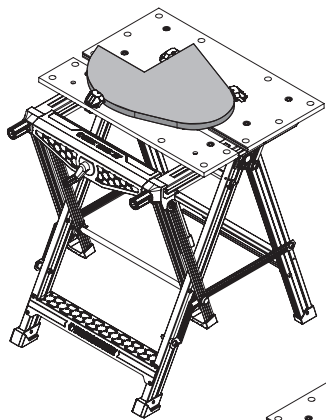
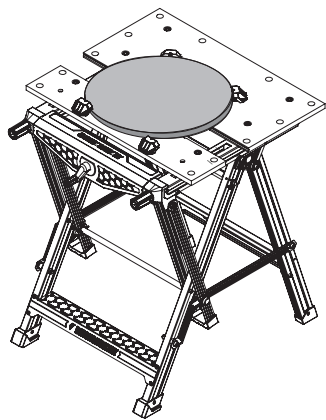
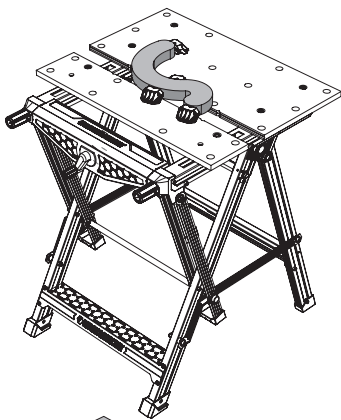
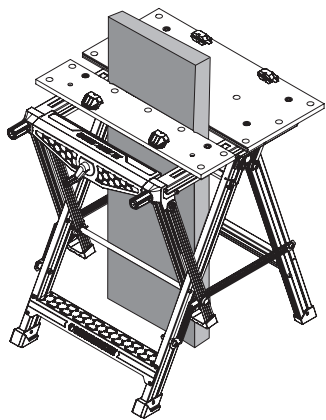

Click
Click
Click
Click

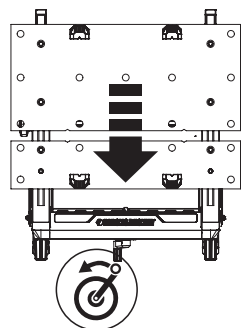

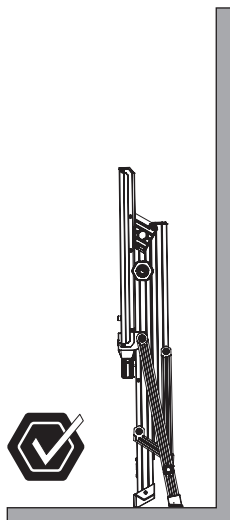
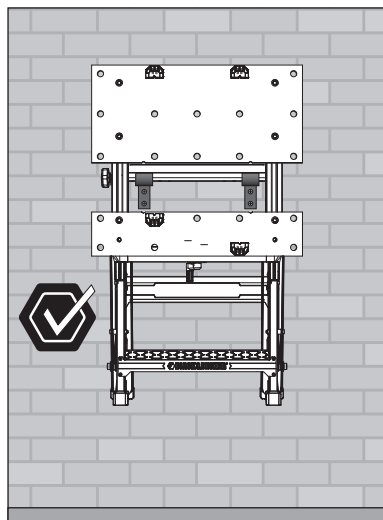
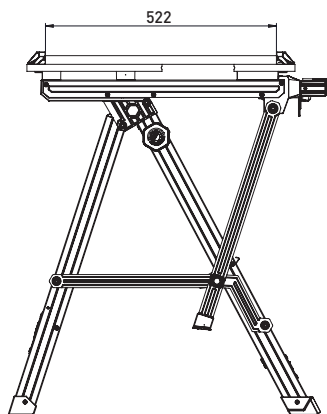
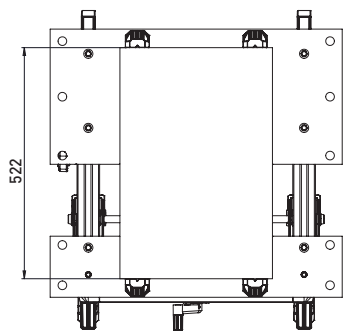
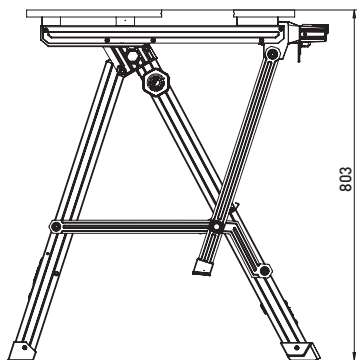
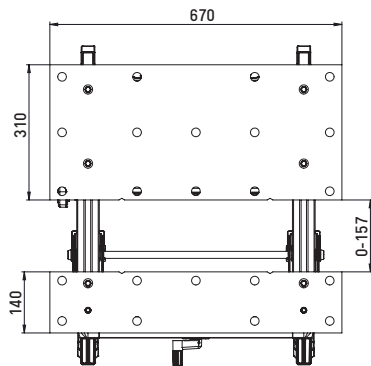

Garantie

Black & Decker assure la qualité de ses produits et vous offre une garantie très élargie. Ce certificat de garantie est un document supplémentaire et ne peut en aucun cas se substituer à vos droits légaux. La garantie est valable sur tout le territoire des États Membres de l'Union Européenne et de la Zone de Libre Échange Européenne.

Si un produit Black & Decker s'avère défectueux en raison de matériaux en mauvaises conditions, d'une erreur humaine, ou d'un manque de conformité dans les 24 mois suivant la date d'achat, Black & Decker garantit le remplacement des pièces défectueuses, la réparation des produits usés ou cassés ou remplace ces produits à la convenance du client, sauf dans les circonstances suivantes :

- ◆ Le produit a été utilisé dans un but commercial, professionnel, ou a été loué;
- ◆ Le produit a été mal utilisé ou utilisé avec négligence;
- ◆ Le produit a subi des dommages à cause d'objets étrangers, de substances ou à cause d'accidents;
- ◆ Des réparations ont été tentées par des techniciens ne faisant pas partie du service technique de Black & Decker.

Pour avoir recours à la garantie, il est nécessaire de fournir une preuve d'achat au vendeur ou à un réparateur agréé. Pour connaître l'adresse du réparateur agréé le plus proche de chez vous, contactez le bureau Black & Decker à l'adresse indiquée dans ce manuel. Vous pourrez aussi trouver une liste de réparateurs agréés de Black & Decker et de plus amples détails sur notre service après-vente sur le site Internet à l'adresse suivante : www.2helpU.com

Visitez notre site Web www.blackanddecker.fr pour enregistrer votre nouveau produit Black & Decker et être informé des nouveaux produits et des offres spéciales. Pour plus d'informations concernant la marque Black & Decker et notre gamme de produits, consultez notre site www.blackanddecker.fr

Garanzia

Certa della qualità dei suoi prodotti, Black & Decker offre una garanzia eccezionale. Il presente certificato di garanzia è complementare ai diritti legali e non li pregiudica in alcun modo. La garanzia è valida entro il territorio degli Stati membri dell'Unione Europea e dell'EFTA (European Free Trade Area).

Se un prodotto Black & Decker risulta difettoso per qualità del materiale, della costruzione o per mancata conformità entro 24 mesi dalla data di acquisto, Black & Decker garantisce la sostituzione delle parti difettose, provvede alla riparazione dei prodotti se ragionevolmente usurati oppure alla loro sostituzione, in modo da ridurre al minimo il disagio del cliente a meno che:

- ◆ il prodotto non sia stato destinato a usi commerciali, professionali o al noleggio;
- ◆ il prodotto non sia stato usato in modo improprio o scorretto;
- ◆ il prodotto non abbia subito danni causati da oggetti o sostanze estranee oppure incidenti;
- ◆ il prodotto non abbia subito tentativi di riparazione non effettuati da tecnici autorizzati né dall'assistenza Black & Decker.

Per attivare la garanzia è necessario esibire la prova di acquisto al venditore o al tecnico autorizzato. Per individuare il tecnico autorizzato più vicino, rivolgersi alla sede Black & Decker locale, presso il recapito indicato nel presente manuale. Altrimenti, un elenco completo di tutti i tecnici autorizzati Black & Decker e i dettagli completi sui contatti e i servizi post-vendita sono disponibili su Internet all'indirizzo: www.2helpU.com

I clienti che desiderano registrare il nuovo prodotto Black & Decker e ricevere gli aggiornamenti sui nuovi prodotti e le offerte speciali, sono invitati a visitare il sito Web (www.blackanddecker.it). Ulteriori informazioni sul marchio e la gamma di prodotti Black & Decker sono disponibili all'indirizzo www.blackanddecker.it.