

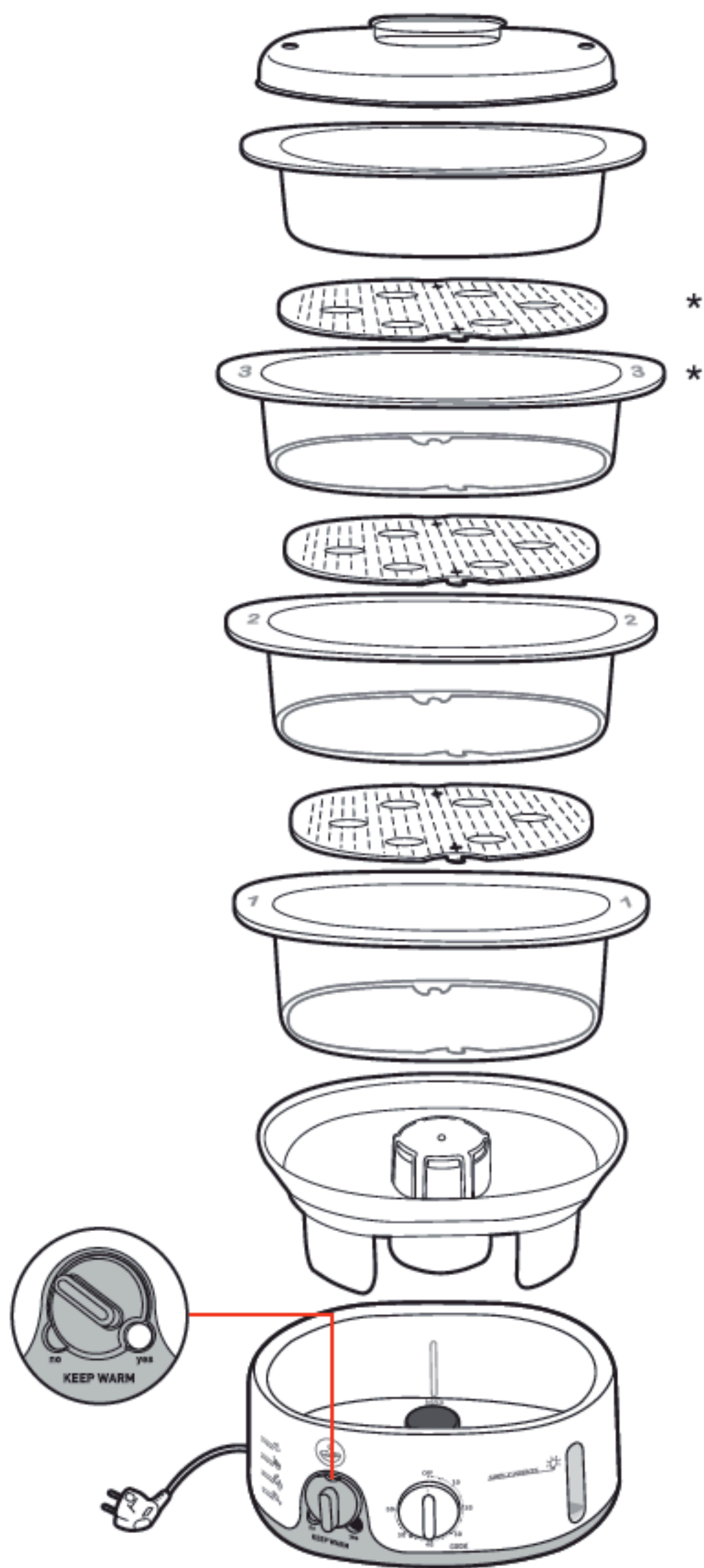

SIMPLY INVENTS



[www.groupeseb.com](http://www.groupeseb.com)



\* Selon modèle - Je nach modell - Afhankelijk van het model

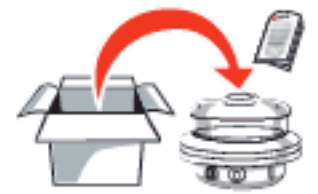

1

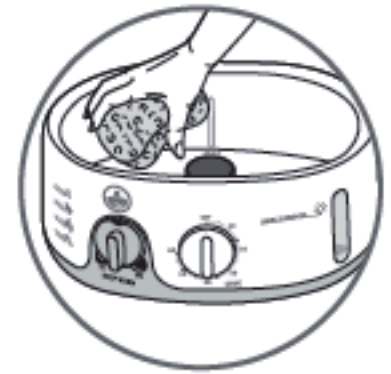
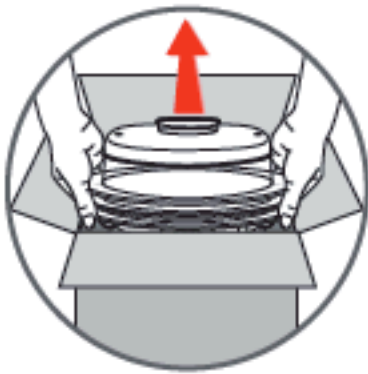

2

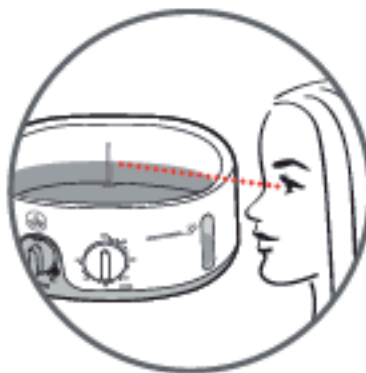

3

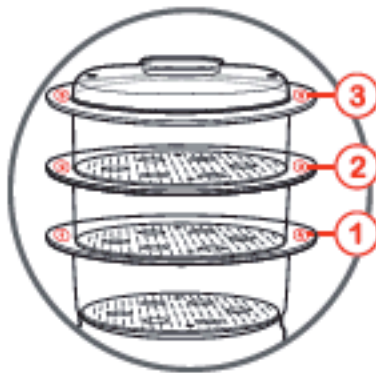

4

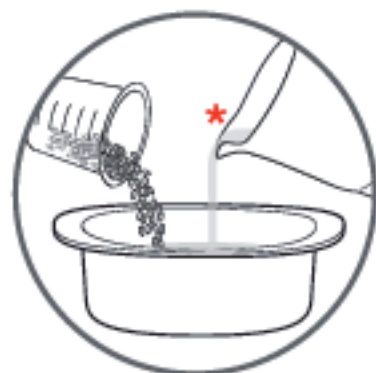

\* Eau - Wasser - Water



5

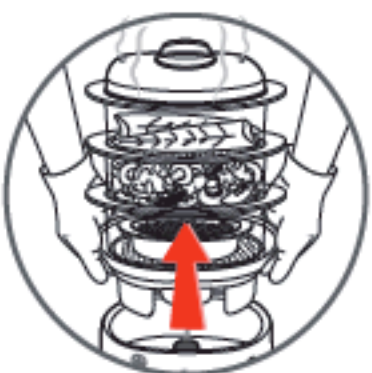

6



\* Eau - Wasser - Water

\*\* Maintien au chaud - Warmhalte-Funktion - Warmhouden

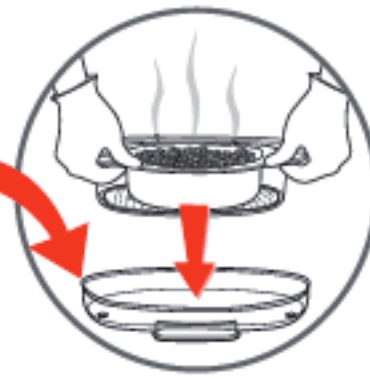

7

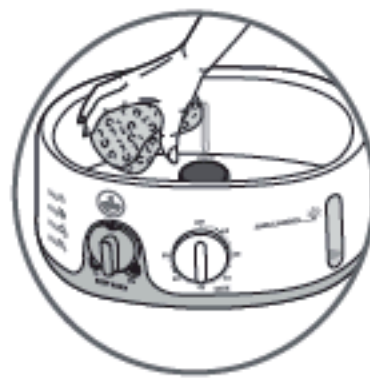
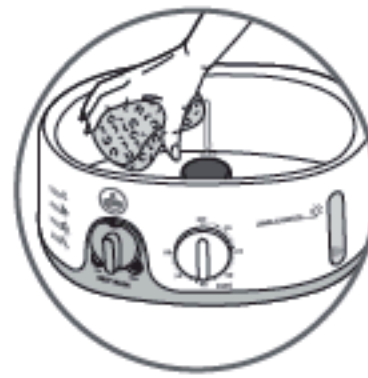
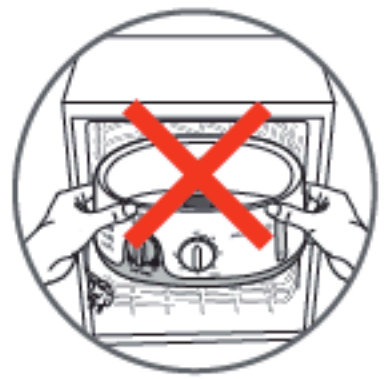



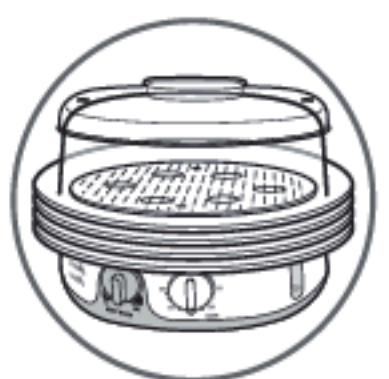
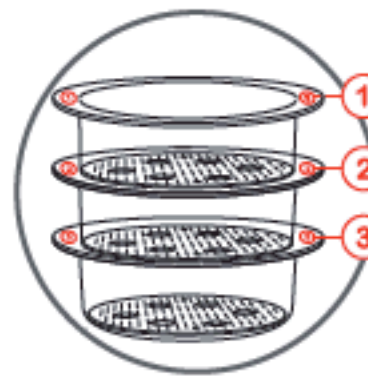





8





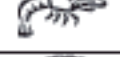



















\* Eau - Wasser - Water  
\*\* Vinaigre - Essig - Azijn







|   |  /Nb |  |
|---|---|---|
|  | 450 g   | 8 - 10 min.   |
|  | 450 g   | 10 - 15 min.  |
|  | 400 g   | 16 - 21 min.  |
|  | 600 g   | 25 - 30 min.  |
|  | 1 kg  | 15 - 20 min.  |
|  | 200 g   | 3 - 7 min.  |
|  | 100 g   | 5 - 10 min.   |

|   |       |              |
|---|-------|--------------|
|  | 450 g | 15 - 20 min. |
|  | 4     | 30 - 35 min. |
|  | 600 g | 20 - 25 min. |
|  | 450 g | 12 - 15 min. |
|  | 500 g | 10 - 15 min. |
|  | 10    | 8 - 10 min.  |
|  | 6     | 15 min.      |

|   |       |              |
|---|-------|--------------|
|  | 3     | 30 - 35 min. |
|  | 400 g | 20 - 25 min. |
|  | 400 g | 16 - 21 min. |
|  | 500 g | 10 - 15 min. |
|  | 600 g | 16 - 19 min. |
|  | 500 g | 10 - 15 min. |
|  | 300 g | 10 - 12 min. |
|  | 500 g | 20 - 22 min. |

|   |  /Nb |  |
|---|---|---|
|    | 500 g   | 15 - 20 min.  |
|    | 500 g   | 10 - 15 min.  |
|    | 500 g   | 15 - 20 min.  |
|    | 500 g   | 10 - 15 min.  |
|    | 400 g   | 20 min.   |
|    | 400 g   | 25 min.   |
|    | 600 g   | 40 - 45 min.  |
|   | 600 g   | 15 - 20 min.  |
|  | 400 g   | 20 - 25 min.  |
|  | 600 g   | 12 - 15 min.  |
|  | 500 g   | 37 - 48 min.  |
|  | 300 g   | 10 - 15 min.  |
|  | 400 g   | 10 - 15 min.  |

|   |       |  |              |
|---|-------|---|--------------|
|  | 200 g | 350ml   | 10 min.      |
|  | 200 g | 400ml   | 20 - 25 min. |
|  | 150 g | 300ml   | 25 - 30 min. |
|  | 150 g | 600ml   | 15 min.      |

|   |       |              |
|---|-------|--------------|
|  | 4     | 10 - 15 min. |
|  | 4     | 20 - 25 min. |
|  | 450 g | 15 - 20 min. |
|  | 4     | 10 - 15 min. |

